

DC PLANETARY GEAR MOTOR

DM-16RP050 粉末冶金 sintering

典型应用/Typical applications :

自动快锁门、装订机、自动电视架、点钞机、聚光灯、卫生纸机、
办公设备、家用电器、自动执行机构
Auto shutter, binding machine, automatic TV rack, money counter,
spotlight, tissue machine, office equipments, household appliances,
automatic actuator



APPEARANCE SIZE

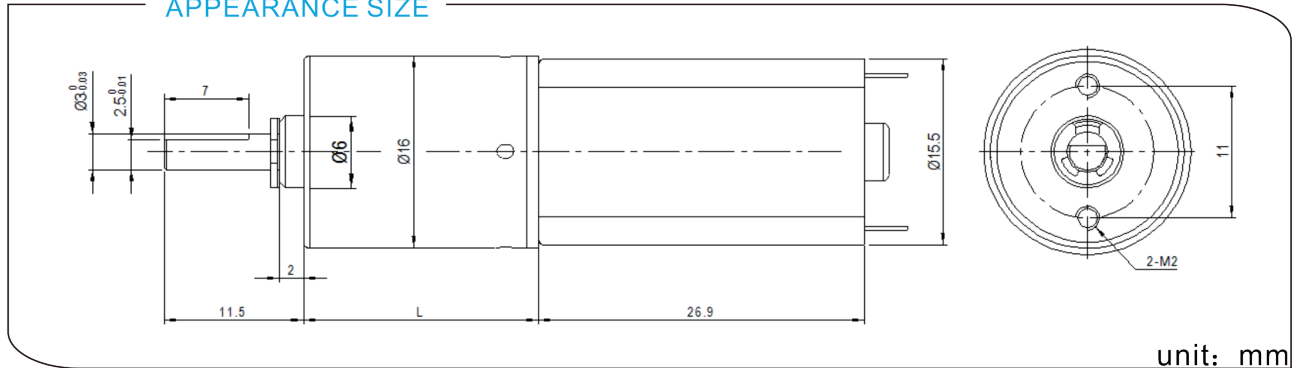

unit: mm

齿轮箱参数/Gearbox Data:

级数 Number of stages	1	2	3	4	5
减数比 Reduction Ratio i	4、4.75	16、22.5	64、79、107	256、361、509	1024、2418
齿轮箱长度 Gearbox Length L (mm)	18.1	22.7	27.3	31.9	36.5
破坏扭力 Breaking Torque(kgf.cm)	2	3	4	5	5
齿轮箱效率 Gearbox Efficiency η	90%	81%	73%	65%	59%

电机参数/Driving Motor Data:

DC Motor Model	Rated	No Load		Max Efficiency Load			Stall		
	电压	电流	转速	电流	转速 (nm)	扭矩	功率	扭矩	电流
	Volt.	Current	Speed	Current	Speed	Torque	P.out	Torque	Current
DM-050-006-9000	6	≤60	9000	≤260	7500	8	0.6	≥30	≥550
DM-050-006-12000	6	≤70	12000	≤300	9300	10	1.0	≥40	≥1000
DM-050-012-9000	12	≤30	9000	≤130	7500	8	0.6	≥30	≥300
DM-050-012-12000	12	≤50	12000	≤200	10000	10	1.0	≥40	≥600

减数电机参数/Geared Motor Data :

Gear Motor Model	额定电压 Rated voltage	No load		Max Efficiency Load			Stall		
		电流	转速	电流	转速 (n)	扭矩	功率	扭矩	电流
		Current	Speed	Current	Speed	Torque	P.out	Torque	Current
DM-16RP050-00313000-22.5K	3	0.24	543.5	0.73	393.6	0.2	0.86	0.77	2.01
DM-16RP050-0069000-107K	6	0.11	76.3	0.29	56.6	0.9	0.52	3.5	0.82
DM-16RP050-00611400-361K	6	0.12	29.3	0.34	20.8	2.58	0.55	8.93	0.86
DM-16RP050-01216000-16K	12	0.18	1037.2	0.51	765.8	0.31	2.53	1.23	1.47
DM-16RP050-01216000-107K	12	0.12	160.5	0.41	127.6	1.44	1.89	7.04	1.53

电机参数仅供参考, 请以实际样板为准; 可以依据客户要求定制参数。

The motor parameters are for reference only, please refer to real measured data;

We can customize parameters according to customer requirements.

减数电机输出转速=直流电机输出转速/齿轮箱减数比; 减数电机输出扭矩=直流电机输出扭矩*齿轮箱减数比*齿轮箱传动效率。

Gear Motor Output Speed=DC Motor Speed/Gear Ratio (n=n_m/i)

Gear Motor Output Torque=DC Motor Torque*Gear Ratio*Gearbox Efficiency. (t=t_m*i*η)